

AG Series

Poppet seal couplers made to the ISO 5675 Standard

Introduction

AKJia's AG Series couplers are designed with a poppet valve for quick and connection and disconnection. They are interchangeable with the ISO A couplers in 1/2" size only, and Other sizes comply with ISO7241 Series A.

Construction

- Carbon steel with trivalent plating
- Fitted with Nitrile seals - NBR
- Also available in ball valve design (See AGB Series)

Features

- Made to ISO 5675 Standard in 1/2" size only
- 1/2" male has internal diverter to prevent reverse flow checking
- Optional zinc nickel plating provides corrosion resistance (500 hours with no red rust in salt spray tests)
- Poppet valves have balanced springs
- Locking ball system allows quick connection
- Bidirectional flow

Application

- Agricultural
- Mobile
- Construction



Specifications

Seal Material	Min. Temp		Max. Temp	
	-40°C	-40°F	106°C	223°F
Nitrile seals*				



Product Number Naming Rules

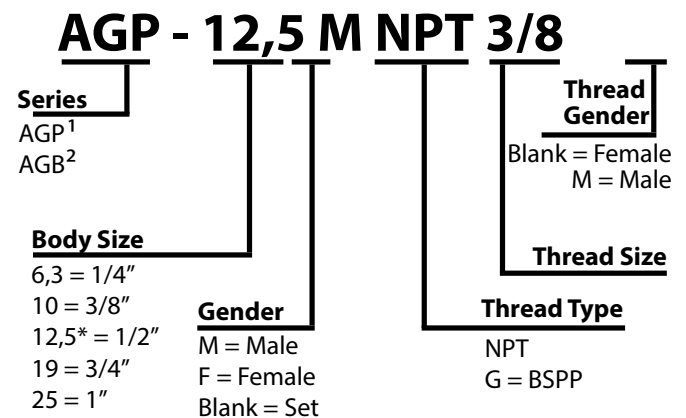

- 1 AGP series with the poppet valve
- 2 AGB Series with the Ball valve
- * is the 1/2" body size comply with ISO 5675 standard - an additional dimensions requirements based on ISO 7241 Series A special for Agricultural tractors and machinery.

Drawing

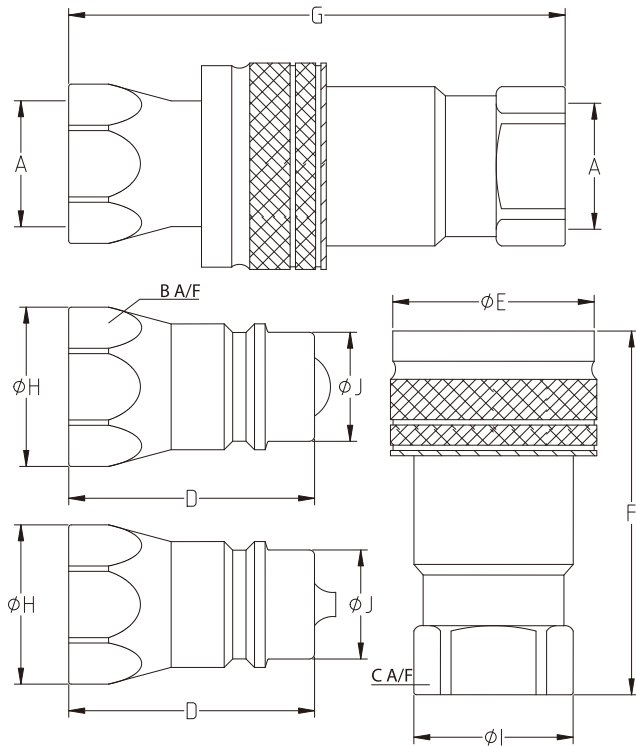

Pressure Drop Characteristics

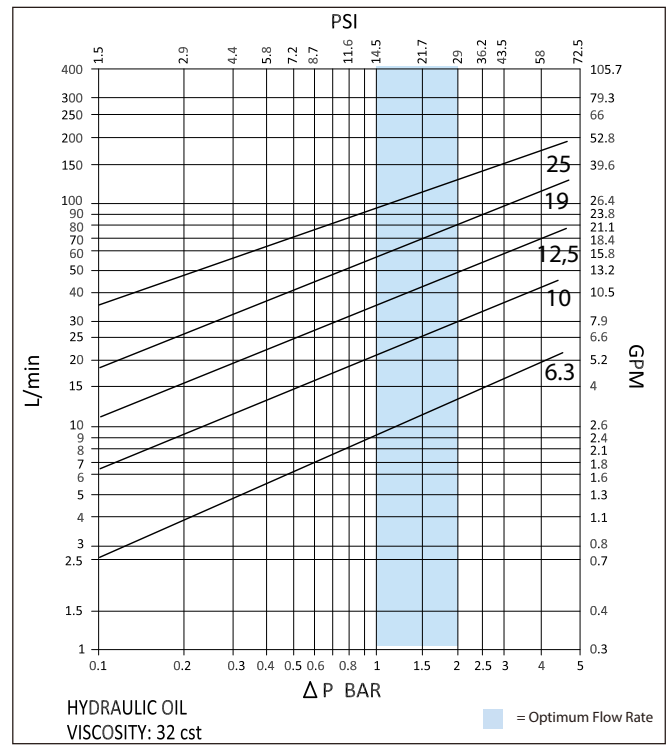

Size	Thread Size (A)	B	C	D	ØE	F	G	ØH	ØI	ØJ	Maximum Working Pressure	Burst Pressure (coupled)	Burst Pressure (Male)	Burst Pressure (Female)	
		Dimensions in mm										Bar			
		Dimensions in inches										Psi			
AGP-6,3	1/4"	19	22	36.5	28	55.5	74.5	21	23.8	14	375	1600	1600	1600	
		0.7	0.9	1.4	1.1	2.2	2.9	0.8	0.9	0.6	5437.5	23200	23200	23200	
AGP-10	3/8"	24	24	40	34	60.5	80.5	26.5	30	19	350	1450	1300	1300	
		0.9	0.9	1.6	1.3	2.4	3.2	1	1.2	0.7	5075	21025	18850	18850	
AGP-12,5	1/2"	27	27	43.5	38.5	66	88	30	30	20.5	320	1300	1500	1400	
		1.1	1.1	1.7	1.5	2.6	3.5	1.2	1.2	0.8	4640	18850	21750	20300	
AGP-19	3/4"	34	34	53.5	48	82.5	108.5	38	38	29	300	1200	1100	1100	
		1.3	1.3	2.1	1.9	3.2	4.3	1.5	1.5	1.1	4350	17400	15950	15950	
AGP-25	1"	41	41	64	56.5	98	129	44	47.5	31	275	1100	1000	1000	
		1.6	1.6	2.5	2.2	3.9	5.1	1.7	1.9	1.2	3987.5	15950	14500	14500	
AGB-6,3	1/4"	19	19	36	27.5	53.5	72.5	21	21.8	14	350	1550	1550	1550	
		0.7	0.7	1.4	1.1	2.1	2.9	0.8	0.9	0.6	5075	22475	22475	22475	
AGB-10	3/8"	24	24	40	34	63.2	83	26.6	27.2	19	300	1400	1250	1250	
		0.9	0.9	1.6	1.3	2.5	3.3	1	1.1	0.7	4350	20300	18125	18125	
AGB-12,5	1/2"	27	27	43.5	38.5	66	88	30	30	20.5	275	1250	1200	1200	
		1.1	1.1	1.7	1.5	2.6	3.5	1.2	1.2	0.8	3987.5	18125	17400	17400	
AGB-19	3/4"	34	34	54	48.5	83	108.5	38	38	28	275	1150	1050	1050	
		1.3	1.3	2.1	1.9	3.3	4.3	1.5	1.5	1.1	3987.5	16675	15225	15225	
AGB-25	1"	41	41	63.5	56	96.5	129	44	44	31	250	1050	950	950	
		1.6	1.6	2.5	2.2	3.8	5.1	1.7	1.7	1.2	3625	15225	13775	13775	