

INTERNATIONAL  
STANDARD

ISO  
7241

Second edition  
2023-07

---

---

**Hydraulic fluid power — Dimensions  
and requirements of quick-action  
couplings**

*Transmissions hydrauliques — Dimensions et exigences des raccords  
rapides*



Reference number  
ISO 7241:2023(E)

© ISO 2023



**COPYRIGHT PROTECTED DOCUMENT**

© ISO 2023

All rights reserved. Unless otherwise specified, or required in the context of its implementation, no part of this publication may be reproduced or utilized otherwise in any form or by any means, electronic or mechanical, including photocopying, or posting on the internet or an intranet, without prior written permission. Permission can be requested from either ISO at the address below or ISO's member body in the country of the requester.

ISO copyright office  
CP 401 • Ch. de Blandonnet 8  
CH-1214 Vernier, Geneva  
Phone: +41 22 749 01 11  
Email: [copyright@iso.org](mailto:copyright@iso.org)  
Website: [www.iso.org](http://www.iso.org) A

Published in Switzerland

# Contents

	Page
<b>Foreword</b> .....	<b>iv</b>
<b>Introduction</b> .....	<b>v</b>
<b>1 Scope</b> .....	<b>1</b>
<b>2 Normative references</b> .....	<b>1</b>
<b>3 Terms and definitions</b> .....	<b>1</b>
<b>4 Dimensional requirements</b> .....	<b>2</b>
<b>5 Performance requirements</b> .....	<b>6</b>
<b>6 Additional requirements for Series A quick-action couplings for use in agricultural machinery applications</b> .....	<b>7</b>
6.1 General.....	7
6.2 Connecting and disconnecting.....	8
6.3 Fluid loss.....	8
6.4 Valve performance.....	8
<b>7 Workmanship</b> .....	<b>8</b>
<b>8 Designation</b> .....	<b>8</b>
<b>9 Marking</b> .....	<b>9</b>
<b>10 Identification statement</b> (reference to this document).....	<b>9</b>
<b>Bibliography</b> .....	<b>10</b>

## Foreword

ISO (the International Organization for Standardization) is a worldwide federation of national standards bodies (ISO member bodies). The work of preparing International Standards is normally carried out through ISO technical committees. Each member body interested in a subject for which a technical committee has been established has the right to be represented on that committee. International organizations, governmental and non-governmental, in liaison with ISO, also take part in the work. ISO collaborates closely with the International Electrotechnical Commission (IEC) on all matters of electrotechnical standardization.

The procedures used to develop this document and those intended for its further maintenance are described in the ISO/IEC Directives, Part 1. In particular, the different approval criteria needed for the different types of ISO documents should be noted. This document was drafted in accordance with the editorial rules of the ISO/IEC Directives, Part 2 (see [www.iso.org/directives](http://www.iso.org/directives)).

Attention is drawn to the possibility that some of the elements of this document may be the subject of patent rights. ISO shall not be held responsible for identifying any or all such patent rights. Details of any patent rights identified during the development of the document will be in the Introduction and/or on the ISO list of patent declarations received (see [www.iso.org/patents](http://www.iso.org/patents)).

Any trade name used in this document is information given for the convenience of users and does not constitute an endorsement.

For an explanation of the voluntary nature of standards, the meaning of ISO specific terms and expressions related to conformity assessment, as well as information about ISO's adherence to the World Trade Organization (WTO) principles in the Technical Barriers to Trade (TBT), see [www.iso.org/iso/foreword.html](http://www.iso.org/iso/foreword.html).

This document was prepared by Technical Committee ISO/TC 131, *Fluid power systems*, Subcommittee SC 4, *Connectors and similar products and components*.

This second edition cancels and replaces the first edition (ISO 7241:2014), which has been technically revised.

The main changes are as follows:

- nominal size designations 20, 40, 50 have been replaced by 19, 38, 51 in accordance with ISO 4397;
- impulse pressure test type has been added in accordance with ISO 6803;
- a mistake in [Table 7](#) has been corrected (two values were inverted);
- minor graphical updates.

Any feedback or questions on this document should be directed to the user's national standards body. A complete listing of these bodies can be found at [www.iso.org/members.html](http://www.iso.org/members.html).

## Introduction

In hydraulic fluid power systems, power is transmitted and controlled through a liquid under pressure within an enclosed circuit. Quick-action couplings are used to join or separate fluid conductors quickly and without the use of tools or special devices.

When hydraulic quick-action couplings are used on agricultural machinery, the female half is normally assembled on the tractor and the male half is normally assembled on the tractor attachment.



# Hydraulic fluid power — Dimensions and requirements of quick-action couplings

## 1 Scope

This document specifies the interface dimensions and basic performance requirements for two series of hydraulic quick-action couplings. Both series are in widespread use and have similar technological advantages:

- Series A is used predominantly in Europe and is preferred worldwide for agricultural and forestry machinery. This document specifies additional requirements for Series A for use in the agricultural machinery applications given in ISO 5675.
- Series B is used predominantly in North America and in the chemical industry.

## 2 Normative references

The following documents are referred to in the text in such a way that some or all of their content constitutes requirements of this document. For dated references, only the edition cited applies. For undated references, the latest edition of the referenced document (including any amendments) applies.

ISO 3448, *Industrial liquid lubricants — ISO viscosity classification*

ISO 5598, *Fluid power systems and components — Vocabulary*

ISO 5675, *Agricultural tractors and machinery — General purpose quick-action hydraulic couplers*

ISO 6803, *Rubber or plastics hoses and hose assemblies — Hydraulic-pressure impulse test without flexing*

ISO 18869, *Hydraulic fluid power — Test methods for couplings actuated with or without tools*

## 3 Terms and definitions

For the purposes of this document, the terms and definitions given in ISO 5598 and the following apply.

ISO and IEC maintain terminology databases for use in standardization at the following addresses:

- ISO Online browsing platform: available at <https://www.iso.org/obp>
- IEC Electropedia: available at <https://www.electropedia.org/>

### 3.1

#### **coupling valve opening force**

maximum force required to fully open the hydraulic quick-action coupling valve when the pressure inside the coupling is at zero

### 3.2

#### **female half**

receptacle portion of a quick-action coupling which normally includes the mechanism to lock the two halves of quick-action coupling together

### 3.3

#### **interface**

portion of a coupling half that establishes and controls interchangeability

3.4

**male half**

probe portion of a quick-action coupling which fits and locks into the *female half* (3.2)

**4 Dimensional requirements**

4.1 Dimensional requirements for Series A hydraulic quick-action couplings are shown in [Figure 1](#) and given in [Table 1](#).

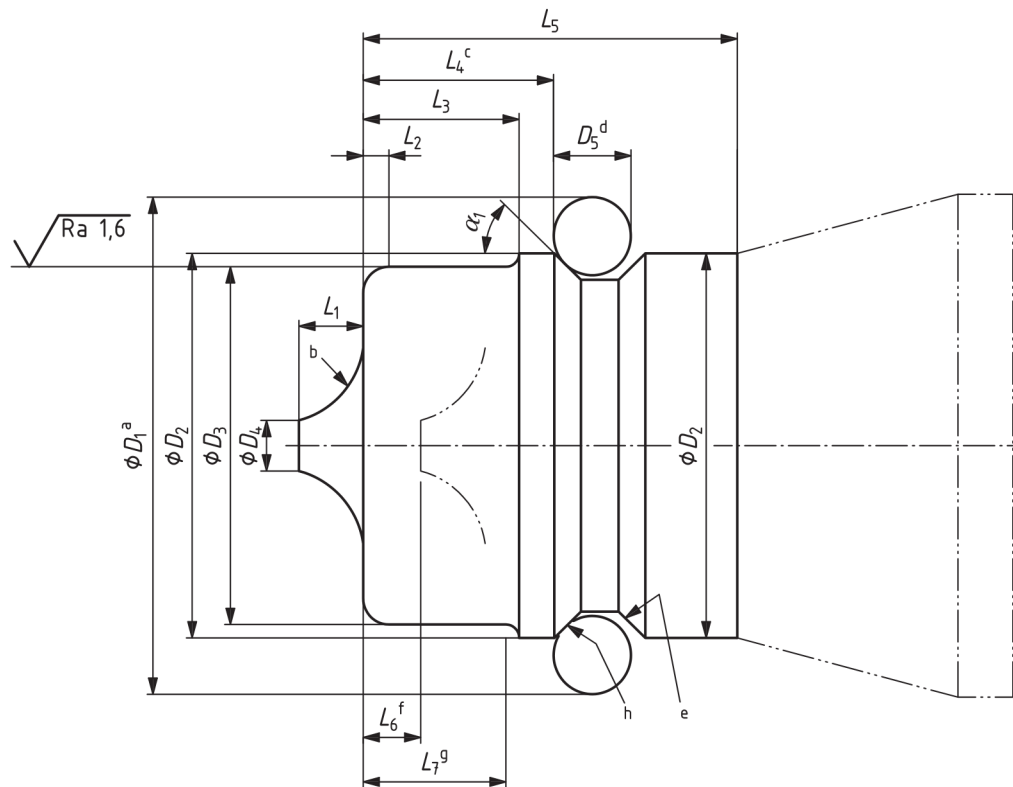

- a Dimension  $D_1$  is the gauge diameter.
- b The shape of the valve is optional, and dimension  $D_4$  is used unless the valve has a spherical form.
- c Dimension  $L_4$  is measured to the ball.
- d Dimension  $D_5$  is the diameter of the gauge ball.
- e The shape of the groove that receives the bearings in the coupled position is left to the manufacturer.
- f Maximum valve travel against stop.
- g Minimum length of diameter  $D_3$ .
- h Minimum hardness shall be 86HR 15N at ball contact point. See ISO 6508-1.

Note Surface roughness: see ISO 21920-1.

**Figure 1 — Dimensional requirements for Series A couplings**



**Table 1 — Dimensional requirements for Series A couplings**

Dimensions in millimetres

Size <sup>a</sup>	$D_1$	$D_2$	$D_3$	$D_4$ <sup>b</sup> min.	$D_5 \pm 0,002\ 5$	$L_1$ max.	$L_2$ <sup>c</sup>	$L_3$	$L_4$	$L_5$ min.	$L_6$ max.	$L_7$ min.	$\alpha_1$
6,3	18,7	12,9 13	11,73 11,86	1,9	3,969	2,8	0,7 1,5	5,5 5,7	6,6 6,8	14,5	0,5	3,7	44° 46°
10	24,1	18,3 18,4	17,2 17,3	3	3,969	3,8	0,7 1,5	8,8 9	9,8 10	18	0,5	7	
12,5	30,3	23,66 23,74	20,48 20,56	4,5	4,763	4	0,7 1,5	9,2 9,4	11,6 11,8	24	0,5	8	
19	37,1	30,4 30,5	29 29,1	5,4	4,763	7,2	1 2,5	15,9 16,1	17,5 17,7	27,5	0,6	13,7	
25	43,0	36,5 36,6	34,21 34,34	7,8	4,763	8,5	1,5 3	19,7 20	22,8 23	34	0,7	16,3	
31,5	56,0	47,7 47,8	44,9 45	8,9	6	11	2 4,5	24,9 25,1	28,4 28,6	43	0,7	24	
38	68,5	57,5 57,6	54,9 55	9,9	8	13	3 6	30,6 30,8	33,7 33,9	51	0,8	29,6	
51	83,7	69,9 70	65 65,1	9,9	10	16,6	3 7	35 35,2	39,6 39,8	61	0,8	34	

<sup>a</sup> The size designation corresponds to the nominal size of the hose recommended for use with the coupling, see ISO 4397.  
<sup>b</sup> Use dimension  $D_4$  unless the valve has a spherical form; spherical form is not preferred.  
<sup>c</sup> Radius or chamfer length. Radius with chamfer is optional.

4.2 Additional dimensional requirements for Series A hydraulic quick-action couplings used in agricultural applications are shown in Figure 2 and given in Table 2.

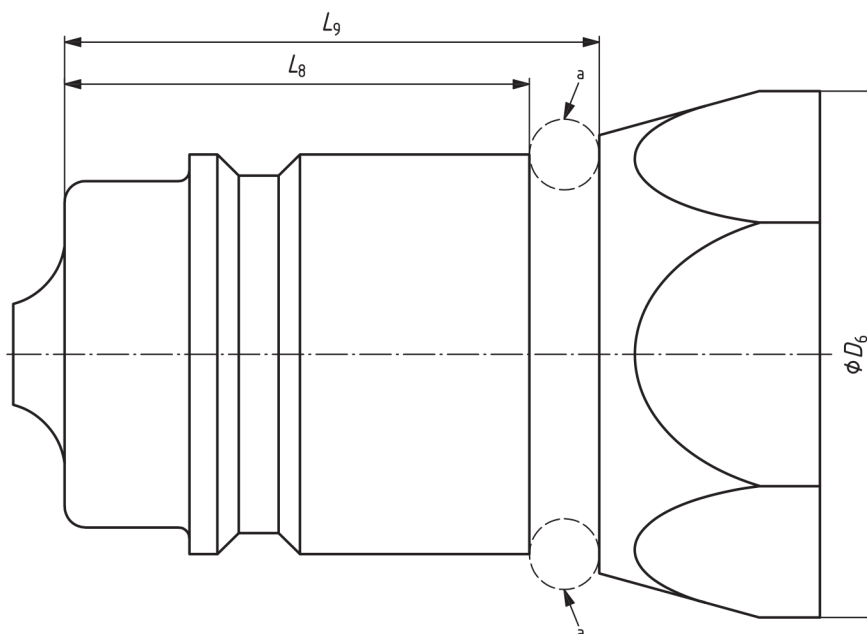

<sup>a</sup> Shape of neck between  $L_8$  and  $L_9$  is optional but shall be circular to accommodate dust sealing.

**Figure 2 — Additional dimensional requirements for Series A couplings used in agricultural applications**

**Table 2 — Additional dimensional requirements for Series A couplings used in agricultural applications**

Dimensions in millimetres

Size <sup>a</sup>	$D_6$ max.	$L_8$ min.	$L_9$ min.
12,5	31	28,5	32,7
19	38	27,5	—

<sup>a</sup> The size designation corresponds to the nominal size of the hose recommended for use with the coupling, see ISO 4397.

4.3 Dimensional requirements for Series B hydraulic quick-action couplings are shown in [Figures 3](#) and [4](#), and given in [Tables 3](#) and [4](#).

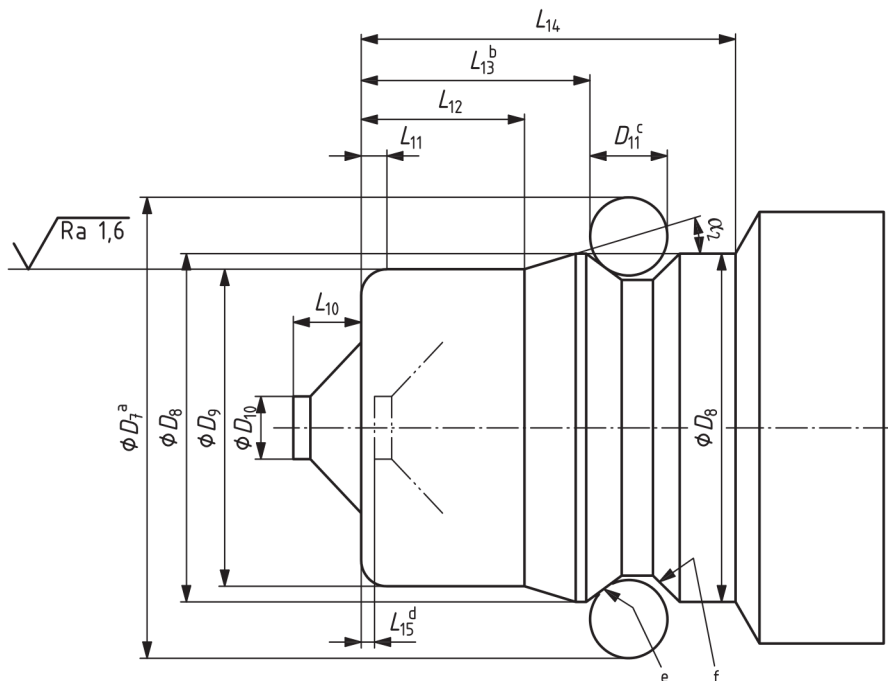

- a Dimension  $D_7$  is the gauge diameter.
- b Dimension  $L_{13}$  is measured to the ball.
- c Diameter  $D_{11}$  is the diameter of the gauge ball.
- d Valve is flush to minus from end of coupling when against stop.
- e Minimum hardness shall be 86HR 15N at ball contact point. See ISO 6508-1.
- f The shape of the groove that receives the bearings in the coupled position is left to the manufacturer.

Note Surface roughness: see ISO 21920-1.

**Figure 3 — Dimensional requirements for Series B couplings — Sizes 5 to 25**

Table 3 — Dimensional requirements for Series B couplings — Sizes 5 to 25

Dimensions in millimetres

Size <sup>a</sup>	Gauge diameter $D_7$	$D_8$	$D_9$	$D_{10}$ min.	$D_{11} \pm 0,0025$	$L_{10}$ max.	$L_{11}^b$	$L_{12}$ min.	$L_{13}$	$L_{14}$ min.	$L_{15}$ max.	$\alpha_2$ max.
5	16,69	12,09 12,19	10,8 10,9	2,16	3,175	2,79	0,64 1,32	7,87	11,28 11,48	18,92	0,5	16°
6,3	21,21	15,6 15,7	14,1 14,2	2,54	3,967	4,06	1,07 1,73	9,65	13,41 13,61	22,1	0,5	
10	26,87	20,04 20,14	19 19,1	3,05	4,763	4,83	1,07 1,73	12,45	15,52 15,72	24,89	0,5	
12,5	33,45	25,65 25,76	23,44 23,55	4,57	5,555	5,08	1,07 1,73	12,19	17,17 17,37	27,94	0,5	
19	41,66	32,66 32,77	31,34 31,45	5,08	6,35	7,37	1,45 2,51	18,8	22,86 23,06	35,56	0,6	
25	49,38	40,46 40,56	37,69 37,8	6,1	6,35	8,64	1,45 2,51	20,57	27,36 27,56	40,39	0,7	

<sup>a</sup> The size designation corresponds to the nominal size of the hose recommended for use with the coupling, see ISO 4397.

<sup>b</sup> Radius or chamfer length. Radius with chamfer is optional.

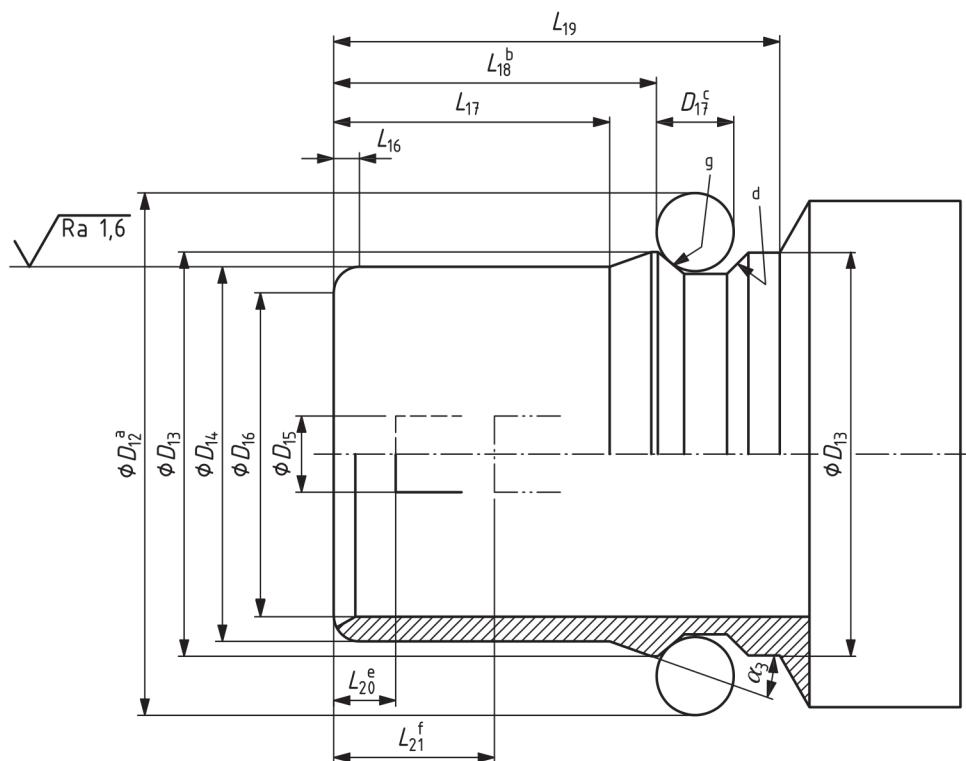

- a Dimension  $D_{12}$  is the gauge diameter.
- b Dimension  $L_{18}$  is measured to the ball.
- c Diameter  $D_{17}$  is the diameter of the gauge ball.
- d The shape of the groove that receives the bearings in the coupled position is left to the manufacturer.
- e Valve closed.
- f Valve open against stop.

g Minimum hardness shall be 86HR 15N at ball contact point. See ISO 6508-1.

Note Surface roughness: see ISO 21920-1.

Figure 4 — Dimensional requirements for Series B couplings — Sizes 38 and 51

Table 4 — Dimensional requirements for Series B couplings — Sizes 38 and 51

Dimensions in millimetres

Size <sup>a</sup>	Gauge diameter $D_{12}$	$D_{13}$	$D_{14}$	$D_{15}$ min.	$D_{16}$	$L_{16}$ <sup>b</sup>	$L_{17}$ min.	$L_{18}$	$L_{19}$ min.	$L_{20}$ max.	$L_{21}$	$D_{17}$ $\pm 0,002\ 5$	$\alpha_3$ max.
38	59,13	47,96 48,06	44,4 44,5	8,89	38,05 38,15	1,4 2,54	32,56	38,91 39,17	53,34	10	26,36 26,87	7,938	21°
51	85,6	66,55 66,68	63,14 63,27	10,16	53 53,16	1,4 2,54	38,1	45,16 45,42	65,02	15	32 32,51	12,7	

<sup>a</sup> The size designation corresponds to the nominal size of the hose recommended for use with the coupling, see ISO 4397.  
<sup>b</sup> Radius or chamfer length. Radius with chamfer is optional.

## 5 Performance requirements

5.1 The performance values specified in this document apply to standard couplings made from carbon steel. The use of any combination of other materials and related performance values shall be agreed between the customer and the manufacturer.

5.2 Series A and B hydraulic quick-action couplings shall meet or exceed the rated pressure and minimum burst pressure ratings given in Tables 5 and 6. See Clause 6 and Table 7 for additional requirements for Series A quick-action couplings for use in agricultural machinery applications.

Table 5 — Performance requirements for Series A couplings

Characteristic	Performance requirements by coupling size <sup>a</sup>							
	6,3	10	12,5	19	25	31,5	38	51
Rated pressure	31,5 MPa (315 bar <sup>b</sup> )	31,5 MPa (315 bar)	25 MPa (250 bar)	25 MPa (250 bar)	20 MPa (200 bar)	20 MPa (200 bar)	16 MPa (160 bar)	10 MPa (100 bar)
Minimum burst pressure	126 MPa (1 260 bar)	126 MPa (1 260 bar)	100 MPa (1 000 bar)	100 MPa (1 000 bar)	80 MPa (800 bar)	80 MPa (800 bar)	64 MPa (640 bar)	40 MPa (400 bar)
Rated flow	3 l/min	23 l/min	45 l/min	100 l/min	189 l/min	288 l/min	379 l/min	757 l/min
Maximum pressure drop at rated flow	130 kPa (1,3 bar)	180 kPa (1,8 bar)	200 kPa (2 bar)	200 kPa (2 bar)	250 kPa (2,5 bar)	200 kPa (2 bar)	200 kPa (2 bar)	200 kPa (2 bar)
Flow rated surge	9 l/min	69 l/min	135 l/min	300 l/min	567 l/min	864 l/min	1 137 l/min	2 271 l/min
Maximum fluid loss per disconnect	1 ml	2 ml	2,5 ml	9 ml	25 ml	60 ml	90 ml	150 ml

<sup>a</sup> The size designation corresponds to the nominal size of the hose recommended for use with the coupling, see ISO 4397.  
<sup>b</sup> 1 bar = 10<sup>5</sup> Pa = 0,1 MPa = 100 kPa; 1 Pa = 1 N/m<sup>2</sup>.

Table 6 — Performance requirements for Series B couplings

Characteristic	Performance requirements by coupling size <sup>a</sup>							
	5	6,3	10	12,5	19	25	38	51
Rated pressure	25 MPa (250 bar)	25 MPa (250 bar)	25 MPa (250 bar)	25 MPa (250 bar)	16 MPa (160 bar)	10 MPa (100 bar)	6,3 MPa (63 bar)	5 MPa (50 bar)
Minimum burst pressure	100 MPa (1 000 bar)	100 MPa (1 000 bar)	100 MPa (1 000 bar)	100 MPa (1 000 bar)	64 MPa (640 bar)	40 MPa (400 bar)	25 MPa (250 bar)	20 MPa (200 bar)
Rated flow	3 l/min	12 l/min	23 l/min	45 l/min	100 l/min	189 l/min	375 l/min	560 l/min
Maximum pressure drop at rated flow	100 kPa (1 bar)	100 kPa (1 bar)	130 kPa (1,3 bar)	130 kPa (1,3 bar)	130 kPa (1,3 bar)	150 kPa (1,5 bar)	180 kPa (1,8 bar)	200 kPa (2 bar)
Flow rate surge	9 l/min	36 l/min	69 l/min	135 l/min	300 l/min	567 l/min	1 125 l/min	1 680 l/min
Maximum fluid loss per disconnect	1 ml	2 ml	2,5 ml	5 ml	10 ml	25 ml	100 ml	200 ml

<sup>a</sup> The size designation corresponds to the nominal size of the hose recommended for use with the coupling, see ISO 4397.

**5.3** The rated pressure shall be verified by pressure impulse test in accordance with ISO 6803 in the coupled and uncoupled conditions conducted in accordance with ISO 18869 for 100 000 cycles.

For the test in the coupled condition, quick-action couplings shall be assembled between the test apparatus and an appropriate hose assembly. The nominal diameter of the hose assemblies shall not exceed one size smaller or larger than the quick-action coupling size (see ISO 4397).

The rated pressure of the hose assemblies shall be equal or higher than the rated pressure of the quick-action couplings.

**5.4** The minimum burst pressure shall be verified by burst pressure testing conducted in accordance with ISO 18869 in the coupled and uncoupled conditions.

**5.5** The maximum pressure drop at rated flow shall be verified by pressure drop testing conducted in accordance with ISO 18869.

**5.6** The rated surge flow rate shall be verified by either long duration surge flow testing or short duration surge flow testing conducted in accordance with ISO 18869.

**5.7** The maximum fluid loss per disconnect shall be verified by testing conducted in accordance with ISO 18869.

## 6 Additional requirements for Series A quick-action couplings for use in agricultural machinery applications

### 6.1 General

Size 12,5 and 19 Series A quick-action couplings designated for use on agricultural machinery shall fulfil the additional requirements specified in this clause, unless otherwise agreed between the customer and the manufacturer. Any other performance requirements shall be in accordance with ISO 5675.

## 6.2 Connecting and disconnecting

Female and male halves shall fulfil the following requirements.

- a) The connecting force measured in accordance with ISO 18869 shall not exceed 200 N with the male half pressurized to 16 MPa (160 bar) and the female half pressurized to 0,25 MPa (2,5 bar) for size 12,5 and 0,10 MPa (1,0 bar) for size 19.
- b) The disconnecting force shall not exceed 1,7 kN for size 12,5 and 2,5 kN for size 19 when subjected to an internal pressure of 17,5 MPa (175 bar). The disconnecting force shall be measured in accordance with ISO 18869.

A special female half capable of connecting and disconnecting under pressure is required to meet these requirements.

## 6.3 Fluid loss

Fluid loss on disconnecting the coupling under pressure shall not exceed the values given in [Table 7](#) when determined in accordance with ISO 18869.

**Table 7 — Maximum fluid loss allowed on disconnecting under pressure**

Maximum fluid loss when disconnecting	Size 12,5	Size 19
Disconnecting at 0,1 MPa (1 bar)	2,5 ml	9,0 ml
Disconnecting at 17,5 MPa (175 bar)	4,0 ml	12,5 ml

## 6.4 Valve performance

**6.4.1** The coupling valve opening force required to fully open the valve in the male part of the coupling when there is no internal pressure in the male part shall not exceed 45 N for size 12,5 and 70 N for size 19.

**6.4.2** The coupling shall not check off (i.e. the valve shall not close) when hydraulic fluid with a viscosity of ISO VG 32, in accordance with ISO 3448, flows from the male part to the female part at a flow rate of 190 l/min for size 12,5 and 250 l/min for size 19.

## 7 Workmanship

The couplings shall be free from defects such as cracks and porosity and shall be deburred. Sharp edges on the outside shall be removed. All surfaces shall meet a surface roughness of Ra 3,2, except where otherwise specified in figures. The finishing of the sealing area in contact with ports and stud ends shall conform to the respective connector standards.

## 8 Designation

Hydraulic quick-action couplings conforming to this document shall be designated as follows:

- a) the word "Coupling";
- b) a reference to this document (i.e. ISO 7241), followed by a spaced hyphen;
- c) the series designation (A or B), followed by a spaced hyphen;
- d) the size;
- e) the designation AG (for agricultural service), if needed.

EXAMPLE A Series A hydraulic quick-action coupling of size 12,5 is designated as follows:

Coupling ISO 7241 - A - 12,5

## 9 Marking

Couplings conforming to this document shall be permanently marked at a minimum with the manufacturer's name, logo or product identification.

## 10 Identification statement (reference to this document)

Use the following statement in test reports, catalogues and sales literature when electing to conform to this document:

*"Hydraulic quick-action coupling dimensions and requirements conform to ISO 7241, Hydraulic fluid power — Dimensions and requirements of quick-action couplings."*

## Bibliography

- [1] ISO 4397, *Fluid power connectors and associated components — Nominal outside diameters of tubes and nominal hose sizes*
- [2] ISO 6508-1, *Metallic materials — Rockwell hardness test — Part 1: Test method*
- [3] ISO 21920-1, *Geometrical product specifications (GPS) — Surface texture: Profile — Part 1: Indication of surface texture*





