



# AGP SERIES

## ISO 5675 AGRICULTURAL QUICK COUPLINGS POPPET VALVE

AGP Series quick couplings are the quick couplings widely used in tractors. The 1/2 and 3/4 size are complying with ISO 5675 standard, and all size are interchangeable with Parker Pionner couplers, Fast NV Series, Holmbury DIN V Series, etc.

## Series AGP //Carbon Steel

Material	Carbon Steel
Surface Finishing	Zinc-Nickel, Zinc-Plating
Standard Seal Material(s)	NBR (Buna-N®) <sup>2</sup>
Working Temperature	-25° C ... +100° C / -13° F ... +212° F
Valve Design	Poppet Valve
Connection	Push and actuate Push Sleeve
Disconnection	Actuate Push Sleeve
Connect Under Pressure	not allowed
Application	Agricultural, Mobile, Construction
ISO Interchange	Only 1/2" Size, ISO 5675

<sup>2</sup> Alternative seal materials are available on request.

## Features

- 1/2" size accepts ISO 5675 universal tips
- Basic operation where coupler sleeve is manually retracted to allow connection with male tip
- Critical parts are hardened
- Ball and poppet valve options
- Protective zinc plating

## Applications

- Agricultural
- Hydraulic Loaders
- Add-on hydraulic circuits
- general industrial

## Technical Data

Series	DN Inch	DN Metric	Q <sub>max</sub>		Working Pressure		bursting puresure coupled		female body		male tip		spillage ml
			l/min	US GPM	bar	psi	bar	psi	bar	psi	bar	psi	
AGP-06	1/4"	6,3	24	6.34	400	5081	1700	24656	1700	24656	1600	23206	1
AGP-10	3/8"	10	46	12.15	350	5076	1500	21756	1700	24656	1500	21756	2.4
AGP-12	1/2"	12,5	100	21.13	350	5076	1200	17404	1400	20305	1000	14504	2.7
AGP-19	3/4"	19	190	50.19	250	3626	1100	15954	1200	17404	1000	14504	8.6
AGP-25	1"	25	250	66.04	250	3626	1000	14504	1100	15954	1200	17404	13.0

## Flow Characteristics

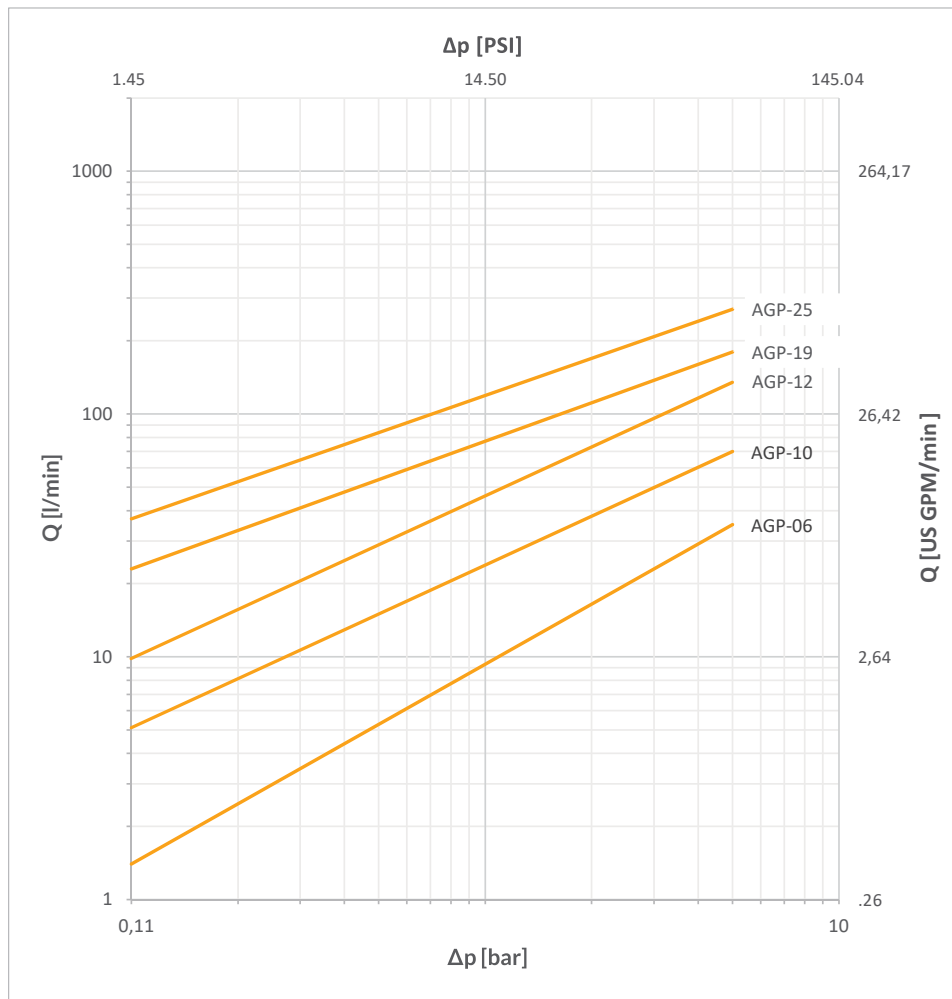





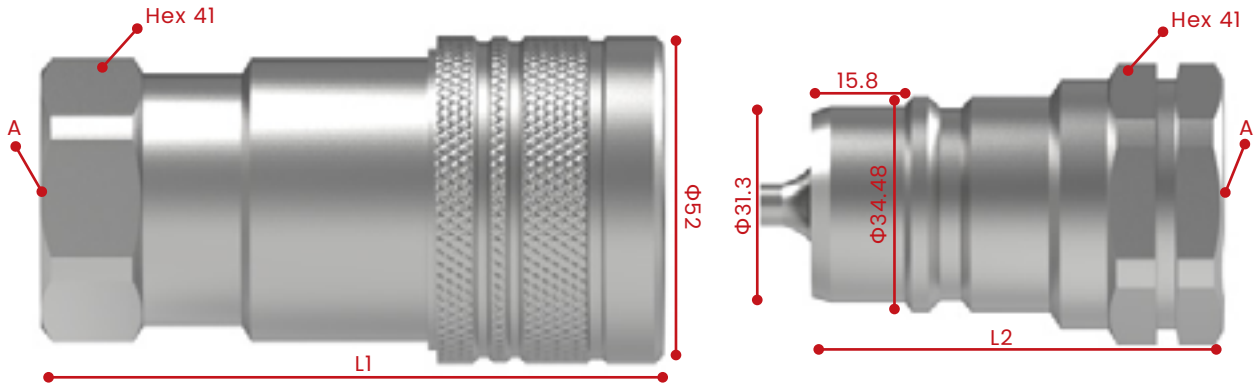

**Series AGP - 25 / Nominal Size 25**

	Port A	Dimensions				Female Body	Weight(g)	Male Tip	Weight(g)
		L1	L2	L3	L4				
Female Thread According to DIN3852 - ANSI B 1.20.3 - SAE J1926-1									
	BSP 1"	99	65.5			AGP-25 F G1	736	AGP-25 M G1	282
	NPT 1"	99	65.5			AGP-25 F NPT1	743	AGP-25 M NPT1	289

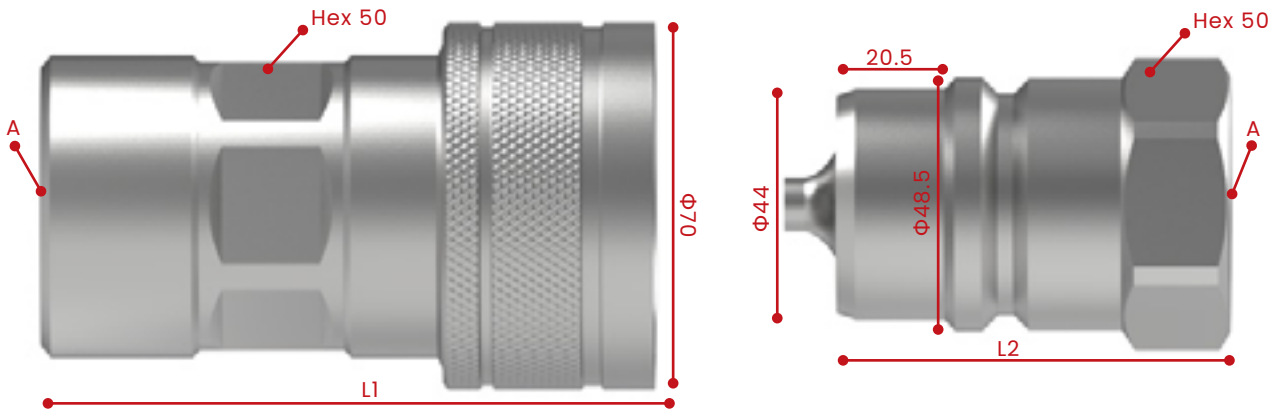

**Series AGP - 31 / Nominal Size 31,5**

	Port A	Dimensions				Female Body	Weight(g)	Male Tip	Weight(g)
		L1	L2	L3	L4				
Female Thread According to DIN3852 - ANSI B 1.20.3 - SAE J1926-1									
	BSP 1" 1/4	117	75			AGP-31 F G1 1/4	1520	AGP-31 M G1 1/4	556
	NPT 1" 1/4	117	75			AGP-31 F NPT1 1/4	1537	AGP-31 M NPT1 1/4	573
	RC 1 1/4"	117	75			AGP-31 F ZG1 1/4	1537	AGP-31 M ZG1 1/4	573

